

- HAZUS
- Pumps
- Hospitals
- Levees
- Airport
- Bus
- Ferry
- Port
- Rail
- Runway
- Railway
- Communication
- Electric Power
- Natural Gas
- Oil
- Potable Water
- Waste Water
- Dams
- Hazmat
- Care Facility
- Emergency Center
- Fire Station
- Police Station
- School
- USGS DLG24K MT Point
- Misc. Transportation
- End of Line
- Helipoint
- Airport
- Measuring Station
- Pump Station
- Steel Pole
- Substation
- USGS DLG24K MS Point
- Manmade Structures
- Boat Ramp
- Building
- Campground
- Drive-in
- House of Worship
- Lake/Pond
- Sunken Wreck
- Mine Shaft
- Picnic Area
- Post Office
- Public Event Site
- Quarry/Open Pit Mine
- Ruins/Cemetery
- School
- Tank
- Tower
- Well
- Pumps
- Hospitals
- USGS DLG24K MT Line
- Misc. Transportation
- Aerial Tramway
- Airport Facility
- Hydro Electric
- Measuring Station
- Pipeline
- Power Station
- Transmission Line
- Pump Station
- Seaplane Area
- Substation
- Telephone Line
- USGS DLG24K MS Line
- Manmade Structures
- Drag Strip
- Drive-in Theater
- Fence Line
- Levee
- Manmade Shoreline
- Breakwater
- Spoil Bank
- Levees
- USGS DLG24K MS
- Manmade Structures
- Boat Ramp
- Breakwater
- Urban Area
- Large Facility
- Cemetery
- Church
- Church Complex
- Public Facility
- Large Building
- Hazard Area
- Hospital
- Hospital Complex
- Intricate Surface
- Levee
- School
- School Campus
- Tank
- Town/Village
- Water Works



U.S. DEPARTMENT OF THE INTERIOR
U.S. GEOLOGICAL SURVEY



PASS CHRISTIAN, MS
Topographic Map Prototype

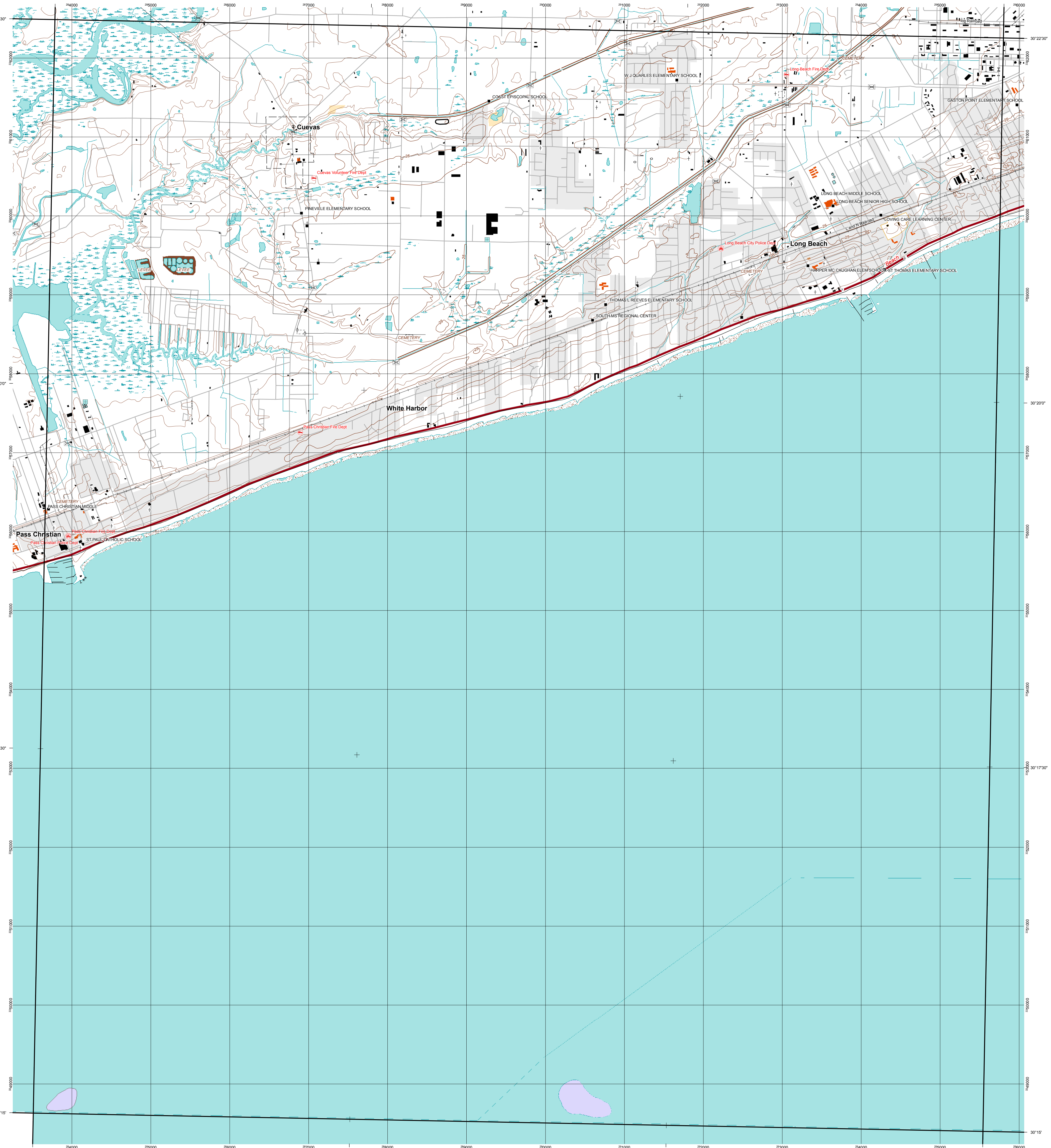

Produced by USGS Product Generation Application
E-mail: usgsmap@usgs.gov

Display projection: Universal Transverse Mercator, Zone 16 North
1000 Meter UTM Grid, Zone 16 North, NAD83

No cartographic or geographic edits were performed on this data

Data - Source
HAZUS - FEMA
Hydrography - USGS 1:24,000 Scale Digital Line Graph
Hypsography - USGS 1:24,000 Scale Digital Line Graph
Transportation - Department of Census
Misc. Transportation - USGS 1:24,000 Scale Digital Line Graph
Manmade Structures - USGS 1:24,000 Scale Digital Line Graph
Labels - Geographic Names Information System

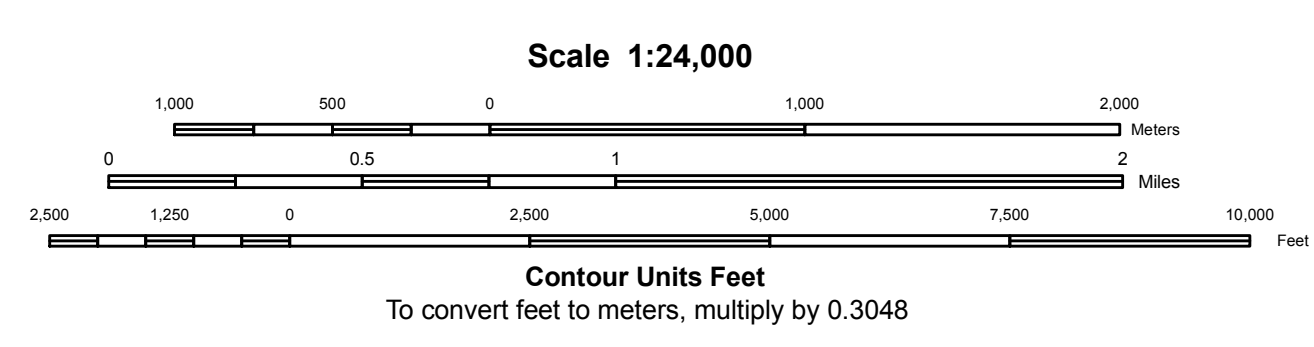

USGS Quadrangle Index

Dedeaux	Sulport NV
Pass Christian	
Isle au Pitre	Cat Island

Road Legend

	Primary Route		Local Street
	Primary Route Separated		Driveway or Service Road
	Secondary Route		Ferry Crossing
	Secondary Route Separated		

Pass Christian, MS
September 15, 2005
5:30 PM CST

Public Data Version
Prototype Product - Not For Sale